

4B. Consideration of adopting Resolution 2026-07 approving MnDOT Cooperative Construction and Maintenance Agreement for TH 25 Bridge as related to I-94 Redecking Project

Prepared by: Public Works Director/City Engineer	Meeting Date: 2/9/2026	<input type="checkbox"/> Consent Agenda Item <input checked="" type="checkbox"/> Regular Agenda Item
Reviewed by: Finance Director	Approved by: City Administrator	

ACTION REQUESTED

Motion to adopt Resolution 2026-07 approve MnDOT Cooperative Construction Agreement No. 1061836 for ongoing maintenance and responsibilities related to the TH 25 Bridge (Bridge No. 86803) reconstruction project.

REFERENCE AND BACKGROUND

MnDOT plans to construct a project on Trunk Highway 25 (TH 25) at Bridge No. 86803 over I-94 in 2027. The project includes bridge redecking, bituminous surfacing, approach panels, sidewalk improvements, lighting replacement, and aesthetic enhancements.

As part of the project, MnDOT has requested that the City of Monticello assume long-term ownership and maintenance responsibilities for several components once construction is completed.

1. Sidewalk System Maintenance: The City will maintain all sidewalk elements over Bridge No. 86803, including:
 - Snow and ice removal
 - Debris removal
 - Crack repair and patching
 - Pedestrian ramp upkeep
 - Grass boulevard mowing
2. Lighting System Ownership & Maintenance: The City will own and maintain the aesthetic bridge lighting system with responsibilities including:
 - LED relamping and replacement
 - Pole and luminaire repairs
 - Electrical cabinet and distribution maintenance
 - Conduit repairs and wiring replacement
 - Utility locates

- Payment of all electrical service costs for the system
 - Aesthetic Feature Maintenance
3. Aesthetic Feature Maintenance: MnDOT will add cast-in-place “Monticello” lettering on the west barrier as well as swan emblems on ornamental railing panels. The City will maintain the new features, including:
- Painting
 - Graffiti removal
 - Replacement of emblems
 - Any repairs required to keep aesthetic elements in an acceptable condition

These responsibilities are consistent with updated standard MnDOT cooperative agreements when cities request enhanced aesthetics or pedestrian accommodations.

- I. **Budget Impact:** There is no local match expected for the project. Ongoing operation and maintenance costs are estimated to be around \$15,000 annually, which would be paid from a combination of the Street Lighting Improvement Fund and General Fund.
- II. **Staff Workload Impact:** The existing sidewalk over the bridge is maintained by MnDOT, including snow removal. The updated agreement will shift responsibility to City crews. The other maintenance agreement components noted will also be added responsibilities, though likely less frequently impacting workload.
- III. **Comprehensive Plan Impact:** Chapter 4, Mobility and Connectivity, supports improvements like redecking the Hwy 25 bridge over I-94 emphasizing safe, efficient transportation infrastructure that maintains regional mobility and enhances long-term corridor performance. Chapter 7, Community Character, Design, and the Arts, encourages aesthetic enhancements to public infrastructure, meaning that incorporating visual design features on the bridge aligns with the city’s goals to strengthen community identity and create attractive gateways.

STAFF RECOMMENDED ACTION

City staff recommend approving the Cooperative Construction and Maintenance Agreement with MnDOT.

SUPPORTING DATA

- Cooperative Maintenance and Construction Agreement and Resolution 2026-07

**STATE OF MINNESOTA
DEPARTMENT OF TRANSPORTATION
And
CITY OF MONTICELLO
COOPERATIVE CONSTRUCTION
AGREEMENT**

State Project Number (SP):	<u>8605-58</u>
Trunk Highway Number (TH):	<u>25=025</u>
Federal Project Number:	<u>BFP 8626(168)</u>
Lighting System Feed Point No.:	<u>City – “C1”</u>

This Agreement is between the State of Minnesota, acting through its Commissioner of Transportation ("State") and the City of Monticello acting through its City Council ("City").

Recitals

1. The State will perform Bridge No. 86803 redecking and repairs, grading, bituminous surfacing, approach panels, sidewalks, and lighting construction and other associated construction upon, along, and adjacent to Trunk Highway No. 25 from Reference Point 67+01.085 to 68+00.092 over I-94 according to State-prepared plans, specifications, and special provisions designated by the State as State Project No. 8605-58 (TH 25=025) ("Project"); and
2. The State has included in its contract an aesthetic lighting system on the barriers of Bridge No. 86803 and the City is willing to maintain the lighting system after completion of the construction. The City will also continue to own and maintain the other two light units south of the bridge from this lighting system that aren't being replaced; and
3. The State has included in its contract bridge aesthetic features such as cast-in-place lettering "Monticello" (community entrance sign) on the outside of the west facing barrier and swan features in the bridge ornamental railing on top of the barriers, and the City is willing to maintain these aesthetic features after completion of the construction; and
4. The City will assume maintenance responsibilities for the sidewalk system over Bridge No. 86803; and
5. Minnesota Statutes § 161.20, subdivision 2 authorizes the Commissioner of Transportation to make arrangements with and cooperate with any governmental authority for the purposes of constructing, maintaining, and improving the trunk highway system.

Agreement

1. Term of Agreement; Survival of Terms; Plans; Incorporation of Exhibits

- 1.1. Effective Date.** This Agreement will be effective on the date the State obtains all signatures required by Minnesota Statutes § 16C.05, subdivision 2.
- 1.2. Expiration Date.** This Agreement will expire when all obligations have been satisfactorily fulfilled.
- 1.3. Survival of Terms.** All clauses which impose obligations continuing in their nature and which must survive in order to give effect to their meaning will survive the expiration or termination of this Agreement, including, without limitation, the following clauses: 3. Maintenance by the City; 6. Liability; Worker Compensation Claims; Insurance; 8. State Audits; 9. Government Data Practices; 10. Governing Law; Jurisdiction; Venue; and 12. Force Majeure.

- 1.4. Plans, Specifications, and Special Provisions.** Plans, specifications, and special provisions designated by the State as State Project No. 8605-58 (TH 25=025) are on file in the office of the Commissioner of Transportation at St. Paul, Minnesota, and incorporated into this Agreement by reference ("Project Plans").
- 1.5. Exhibits.** Exhibit "A" – Lighting, Exhibit "B" – Concrete Barrier Emblem, and Exhibit "C" – Metal Railing Swan Emblem are attached and incorporated into this agreement.

2. Construction by the State

- 2.1. Contract Award.** The State will advertise for bids and award a construction contract to the lowest responsible bidder according to the Project Plans.
- 2.2. Direction, Supervision, and Inspection of Construction.**
- A. Supervision and Inspection by the State.** The State will direct and supervise all construction activities performed under the construction contract, and perform all construction engineering and inspection functions in connection with the contract construction. All contract construction will be performed according to the Project Plans.
- B. Inspection by the City.** The construction covered under this Agreement will be open to inspection by the City. If the City believes the construction covered under this Agreement has not been properly performed or that the construction is defective, the City will inform the State District Engineer's authorized representative in writing of those defects. Any recommendations made by the City are not binding on the State. The State will have the exclusive right to determine whether the State's contractor has satisfactorily performed the construction covered under this Agreement.
- 2.3. Plan Changes, Additional Construction, Etc.**
- A.** The State will make changes in the Project Plans and contract construction and will enter into any necessary addenda and change orders with the State's contractor that are necessary to cause the contract construction to be performed and completed in a satisfactory manner.
- B.** The City may request additional work or changes to the work in the plans as part of the construction contract. Such request will be made by an exchange of letter(s) with the State. If the State determines that the requested additional work or plan changes are necessary or desirable and can be accommodated without undue disruption to the project, the State will cause the additional work or plan changes to be made. The State reserves the right to invoice the City for the cost of any construction contract addenda and any additional City requested work and plan changes, including associated construction engineering, before the completion of the contract construction.
- 2.4. Satisfactory Completion of Contract.** The State will perform all other acts and functions necessary to cause the construction contract to be completed in a satisfactory manner. Acceptance by the State of the completed contract construction will be final, binding, and conclusive upon the City as to the satisfactory completion of the contract construction.
- 2.5. Permits.** The City will submit to the State's Utility Engineer an original permit application for all utilities owned by the City to be constructed hereunder that are upon and within the Trunk Highway Right-of-Way. Applications for permits will be made on State form "Application For Utility Permit On Trunk Highway Right-of-Way" (Form 2525).

3. Maintenance by the City

Upon completion of the project, the City will provide the following without cost or expense to the State:

- 3.1. Sidewalks.** Maintenance of any sidewalk construction, including stamped and colored concrete sidewalk (if any) and pedestrian ramps. Maintenance includes, but is not limited to, snow, ice, and debris removal, patching, crack repair, removing trip hazards (other than panel replacement), cross street pedestrian crosswalk markings, mowing grass boulevards (if any), and any other maintenance activities necessary to perpetuate the sidewalks in a safe, useable, and aesthetically acceptable condition.
- 3.2. Lighting.** Maintenance and ownership of the lighting facility shown in Exhibit "A" – Lighting construction. Maintenance of electrical lighting systems includes everything within the system, from the point of attachment to the power source or utility, to the last light on the feed point, including but not limited to re-lamping of lighting units or replacing of LED luminaires, repair or replacement of all damaged luminaire glassware, loose connections, luminaires when damaged or when ballasts fail, photoelectric control on luminaires, defective starter boards or drivers, damaged fuse holders, blown fuses, knocked down poles including wiring within the poles, damaged poles, pull boxes, underground wire, damaged foundations, equipment pad, installation of approved splices or replacement of wires, repair or extending of conduit, lighting cabinet maintenance including photoelectric cell, electrical distribution system, Gopher State One Call (GSOC) locates, and painting of poles and other equipment. The City will be responsible for the hook up cost and application to secure an adequate power supply to the service pad or pole and will pay all monthly electrical service expenses necessary to operate the lighting facility.
- 3.3. Bridge No. 86803 Aesthetics.** The City will perform maintenance and repair of aesthetic elements on Bridge No. 86803; this includes cast-in-place lettering "Monticello" (community entrance sign) on the outside of the west facing barrier shown in Exhibit "B" – Concrete Barrier Emblem, and swan features in the bridge ornamental railing on top of the barriers shown in Exhibit "C" – Metal Railing Swan Emblem. Maintenance and repair includes, but is not limited to, painting, graffiti removal, emblem replacement, and any other maintenance activities necessary to perpetuate the aesthetic elements in a safe, usable, and aesthetically acceptable condition.

4. Authorized Representatives

Each party's Authorized Representative is responsible for administering this Agreement and is authorized to give and receive any notice or demand required or permitted by this Agreement.

4.1. The State's Authorized Representative will be:

Name, Title: Jamie Hukriede, Assistant District Engineer - Maintenance (or successor)
 Address: 7694 Industrial Park Road, Baxter, MN 56425
 Telephone: 218-828-5700
 Fax: 218-828-5814
 E-Mail: jamie.hukriede@state.mn.us

4.2. The City's Authorized Representative will be:

Name, Title: Matt Leonard, Public Works Director/City Engineer (or successor)
 Address: 505 Walnut Street, Suite 1, Monticello, MN 55362
 Telephone: 763-271-3271
 E-Mail: Matt.Leonard@MonticelloMN.gov

5. Assignment; Amendments; Waiver; Contract Complete

- 5.1. Assignment.** No party may assign or transfer any rights or obligations under this Agreement without the prior consent of the other party and a written assignment agreement, executed and approved by the same parties who executed and approved this Agreement, or their successors in office. The foregoing does not

prohibit the City from contracting with a third party to perform City maintenance responsibilities covered under this Agreement.

- 5.2. Amendments.** Any amendment to this Agreement must be in writing and will not be effective until it has been executed and approved by the same parties who executed and approved the original Agreement, or their successors in office.
- 5.3. Waiver.** If a party fails to enforce any provision of this Agreement, that failure does not waive the provision or the party's right to subsequently enforce it.
- 5.4. Contract Complete.** This Agreement contains all prior negotiations and agreements between the State and the City. No other understanding regarding this Agreement, whether written or oral, may be used to bind either party.

6. Liability; Worker Compensation Claims; Insurance

Each party is responsible for its own acts, omissions, and the results thereof to the extent authorized by law and will not be responsible for the acts, omissions of others, and the results thereof. Minnesota Statutes § 3.736 and other applicable law govern liability of the State. Minnesota Statutes Chapter 466 and other applicable law govern liability of the City. Each party is responsible for its own employees for any claims arising under the Workers Compensation Act.

7. Nondiscrimination

Provisions of Minnesota Statutes § 181.59 and of any applicable law relating to civil rights and discrimination are considered part of this Agreement.

8. State Audits

Under Minnesota Statutes § 16C.05, subdivision 5, the City's books, records, documents, accounting procedures, and practices relevant to this Agreement are subject to examination by the State and the State Auditor or Legislative Auditor, as appropriate, for a minimum of six years from the end of this Agreement.

9. Government Data Practices

The City and State must comply with the Minnesota Government Data Practices Act, Minnesota Statutes Chapter 13, as it applies to all data provided under this Agreement, and as it applies to all data created, collected, received, stored, used, maintained, or disseminated by the City under this Agreement. The civil remedies of Minnesota Statutes §13.08 apply to the release of the data referred to in this clause by either the City or the State.

10. Governing Law; Jurisdiction; Venue

Minnesota law governs the validity, interpretation, and enforcement of this Agreement. Venue for all legal proceedings arising out of this Agreement, or its breach, must be in the appropriate state or federal court with competent jurisdiction in Ramsey County, Minnesota.

11. Termination; Suspension

- 11.1. By Mutual Agreement.** This Agreement may be terminated by mutual agreement of the parties or by the State for insufficient funding as described below.
- 11.2. Termination for Insufficient Funding.** The State may immediately terminate this Agreement if it does not obtain funding from the Minnesota Legislature, or other funding source; or if funding cannot be continued at a level sufficient to allow for the performance of contract construction under the Project. Termination must be by written or fax notice to the City.

11.3. Suspension. In the event of a total or partial government shutdown, the State may suspend this Agreement and all work, activities and performance of work authorized through this Agreement.

12. Force Majeure

No party will be responsible to the other for a failure to perform under this Agreement (or a delay in performance), if such failure or delay is due to a force majeure event. A force majeure event is an event beyond a party's reasonable control, including but not limited to, unusually severe weather, fire, floods, other acts of God, labor disputes, acts of war or terrorism, or public health emergencies.

[The remainder of this page has been intentionally left blank]

CITY OF MONTICELLO

The undersigned certify that they have lawfully executed this contract on behalf of the Governmental Unit as required by applicable charter provisions, resolutions, or ordinances.

By: _____

Title: _____

Date: _____

By: _____

Title: _____

Date: _____

DEPARTMENT OF TRANSPORTATION

Approved:

By: _____
(District Engineer)

Date: _____

COMMISSIONER OF ADMINISTRATION

By: _____
(With Delegated Authority)

Date: _____

INCLUDE COPY OF RESOLUTION APPROVING THE AGREEMENT AND AUTHORIZING ITS EXECUTION.

CITY OF MONTICELLO

RESOLUTION 2026-07

IT IS RESOLVED that the City of Monticello enter into MnDOT Agreement No. 1061836 with the State of Minnesota, Department of Transportation for the following purposes:

To provide for routine maintenance by the City upon, along, and adjacent to Trunk Highway No. 25, the limits of which are defined in said Agreement.

IT IS FURTHER RESOLVED that the Mayor and the _____
(Title)
are authorized to execute the Agreement and any amendments to the Agreement.

CERTIFICATION

I certify that the above Resolution is an accurate copy of the Resolution adopted by the Council of the City of Monticello at an authorized meeting held on the _____ day of _____, 20__, as shown by the minutes of the meeting in my possession.

Subscribed and sworn to me this _____ day of _____, 20__
Notary Public _____
My Commission Expires _____

_____ (Signature)
_____ (Type or Print Name)
_____ (Title)

- NOTE:
1. CONNECTIONS TO NEW BRIDGE LIGHTING TO BE IN HANDHOLES 1 & 2
 2. INPLACE LIGHT UNITS C1 1 AND C1 8 TO HAVE LED LUMINAIRE INSTALLED
 3. PVC COATED RIGID METAL CONDUIT TO BE USED IN BRIDGE
 4. RED 3M LOCATOR BALLS TO BE PLACED IN HANDHOLES (MNDOT PROVIDED)

FOUNDATION AND LIGHTING UNITS					
NO.	STATION	LT.	RT.	LOCATION	LIGHT UNIT TYPE
1	561+35.022		RT.	NB TH 25	9-40
2	565+14.436		RT.	NB TH 25	SPECIAL
3	566+02.016		RT.	NB TH 25	SPECIAL
4	566+89.596		RT.	NB TH 25	SPECIAL
5	566+71.163	LT.		SB TH 25	SPECIAL
6	565+83.584	LT.		SB TH 25	SPECIAL
7	564+96.00	LT.		SB TH 25	SPECIAL
8	561+59.415	LT.		SB TH 25	9-40

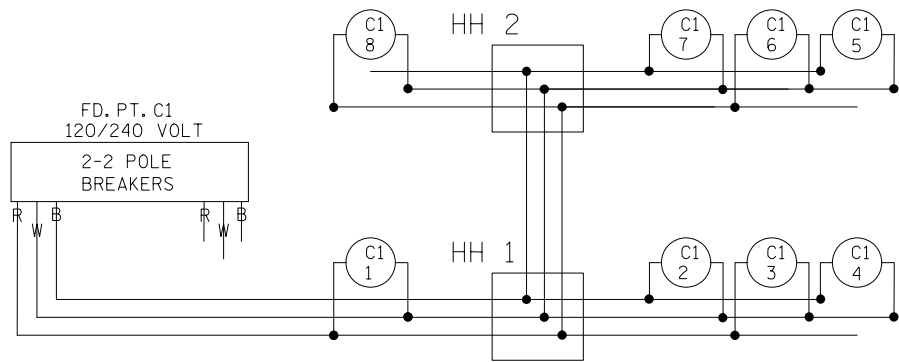

B AND R DENOTE CURRENT CARRYING CONDUCTORS
W DENOTES NEUTRAL CONDUCTOR

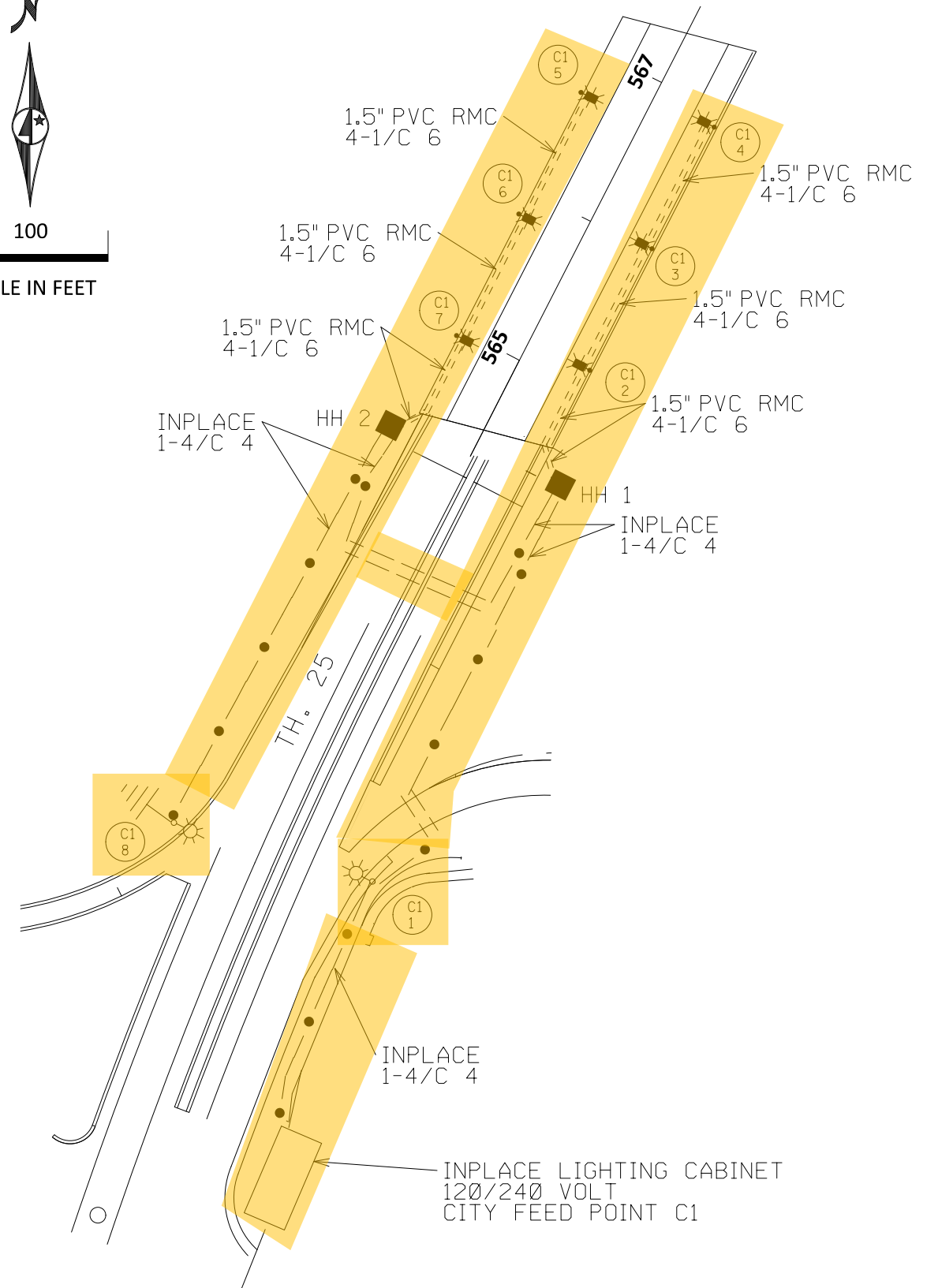
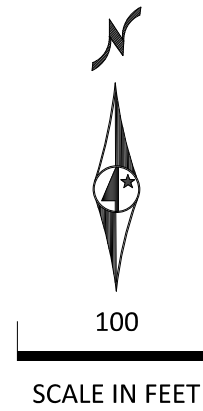
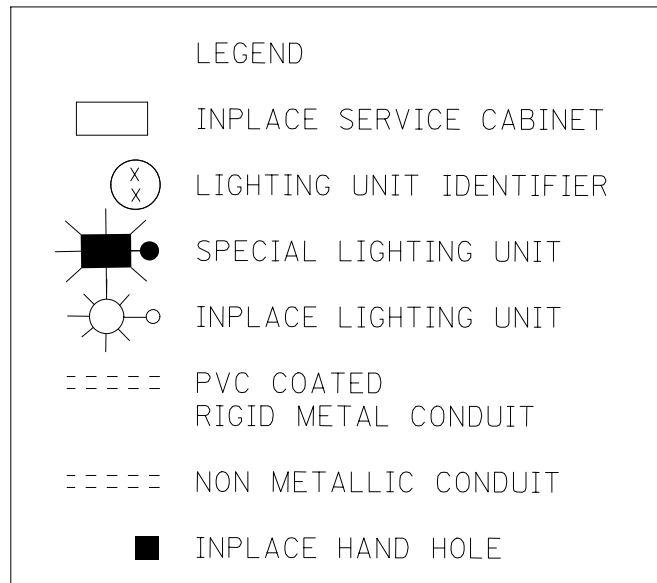

Exhibit A - Lighting

Maintenance and Ownership by the City of Monticello

METER ADDRESS
990 HWY 25 S
MONTICELLO, MN 55362
SYS ID: 24132789

DISTRICT #: \$@DISTRICT@\$
 PLOT NAME: \$\$@PLOTSNAME@\$
 PATH & FILENAME: \$\$\$@PATH+FILENAME@\$\$\$
 PLOTTED/REVISED: \$\$\$@DATE@\$\$\$

Exhibit B - Concrete Emblem

Maintenance by the City of Monticello

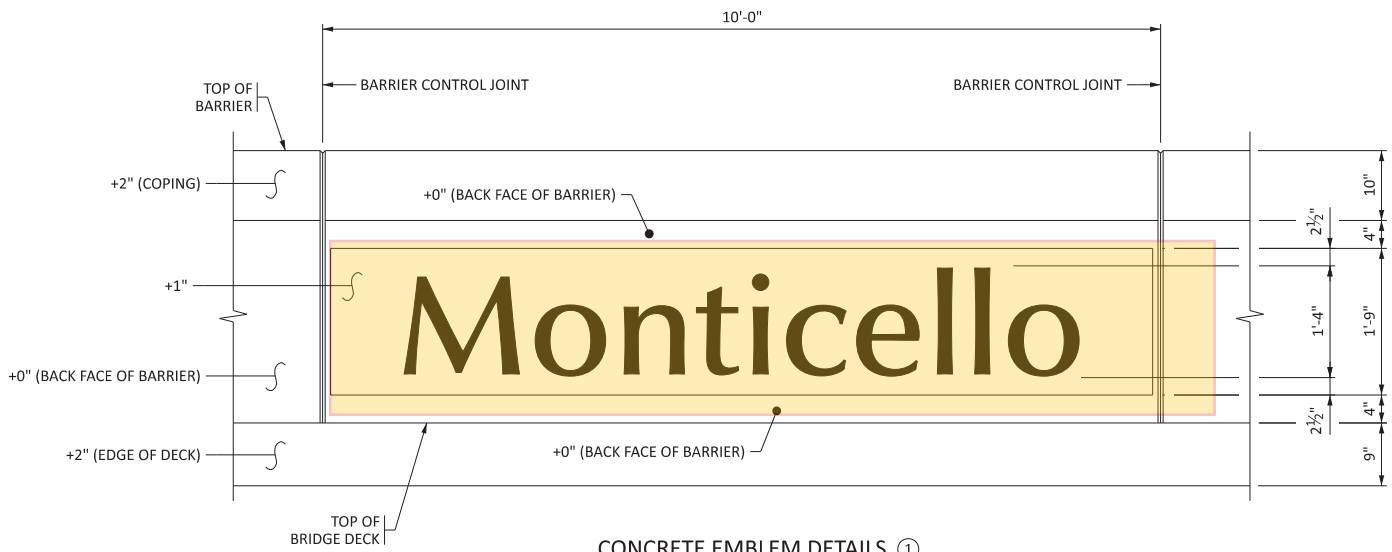

TIME : 9:26:41 PM

PLOTTED : 11/24/2025

PATH & FILENAME : c:\proj\tech\ise\pw_working\pove2\h\1538256.br86803_BEP.dgn

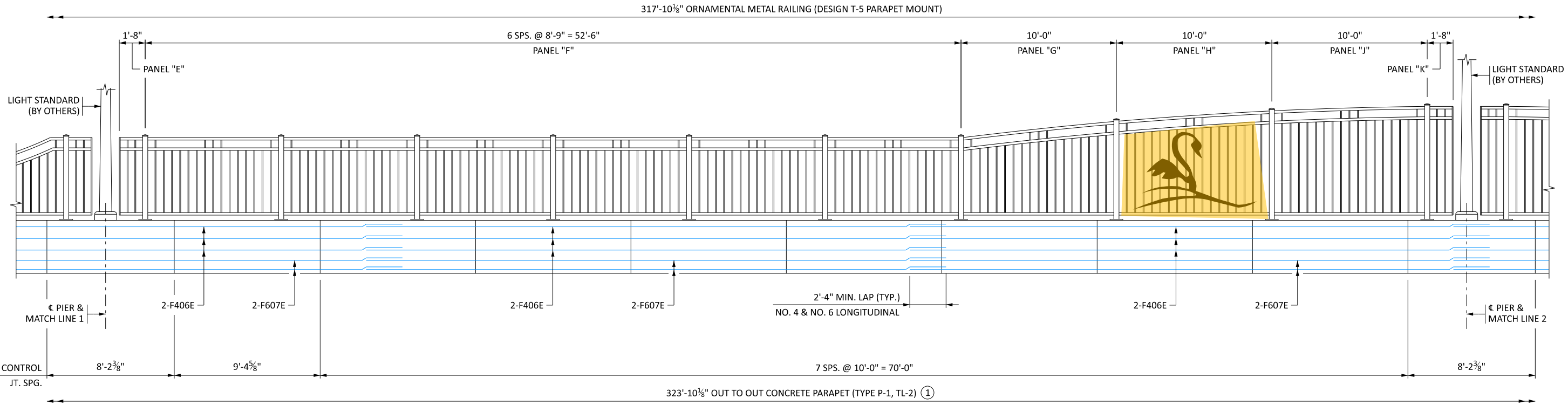
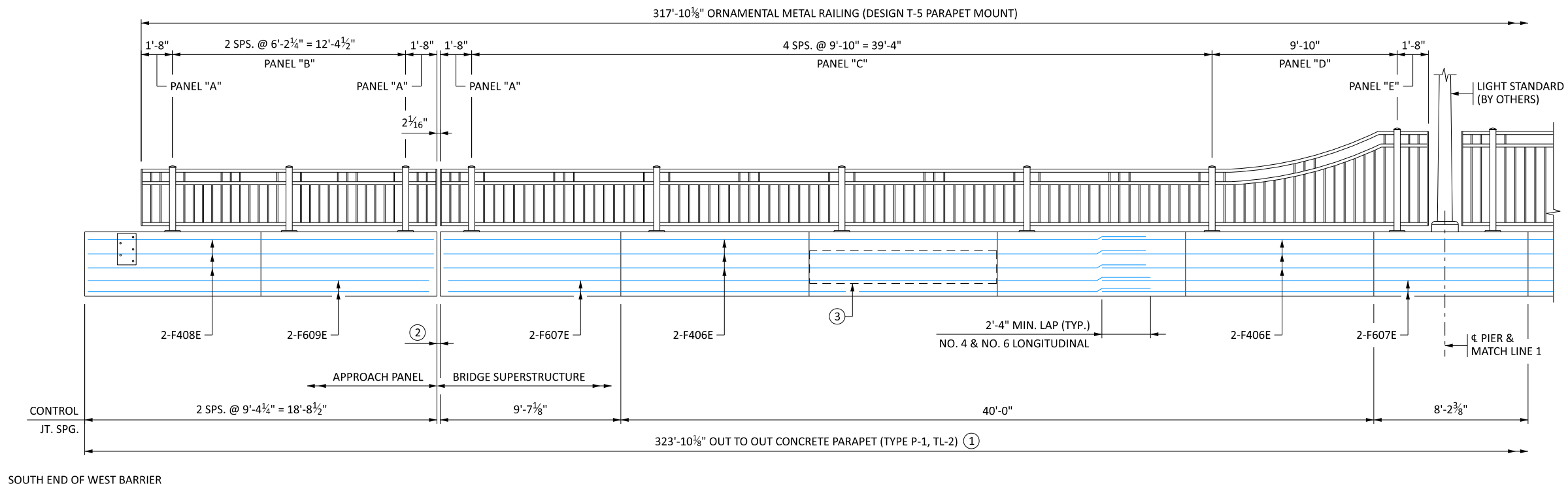

INSIDE ELEVATION CONCRETE PARAPET & ORNAMENTAL RAILING
WEST BARRIER SHOWN (EAST BARRIER SIMILAR)

Exhibit C - Metal Railing Swan Emblem

MAINTENANCE BY CITY OF MONTICELLO

- NOTES:**
- SEE SHEET NO. XX FOR CONCRETE BARRIER AND REINFORCEMENT DETAILS.
 - SEE SHEET NO. XX FOR ORNAMENTAL METAL RAILING DETAILS.
 - SEE SHEET NO. XX FOR RAIL PANEL DETAILS.
 - ① MEASURED ALONG INSIDE FACE OF PARAPET.
 - ② 2" AT ALL TEMPS.
 - ③ SEE SHEET NO. XX FOR DETAILS OF IMPRINTED CONCRETE SIGN. INCLUDED IN ITEM "CONCRETE EMBLEM (SIGNAGE)". LOCATED ON THE WEST BARRIER.

REV. NO.	DATE	REVISION DESCRIPTION	BY	I HEREBY CERTIFY THAT THIS PLAN WAS PREPARED BY ME OR UNDER MY DIRECT SUPERVISION AND THAT I AM A DULY LICENSED PROFESSIONAL ENGINEER UNDER THE LAWS OF THE STATE OF MINNESOTA	CERTIFIED BY: NAME: BRANDON L. DAY LICENSED PROFESSIONAL ENGINEER LIC. NO.: 56027	TITLE: CONCRETE PARAPET & METAL RAILING ELEV. (1 OF 2)	DES: _____ CHK: _____	DR: BEP CHK: _____	APPROVED: _____	BRIDGE NO. 86803
								SHEET NO. 14 OF __ SHEETS		

TIME : 9:26:42 PM
 PLOTTED : 11/24/2025
 PATH & FILENAME : c:\proj\tech\ise\pw_working\pove2\bl\1538256\br86803_BEP.dgn

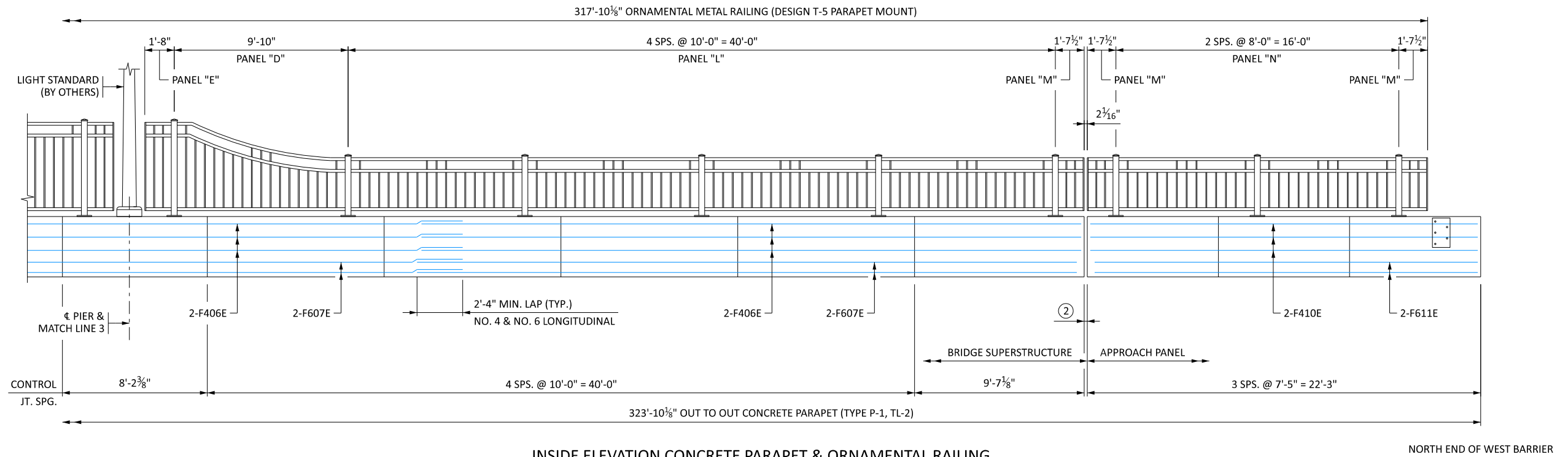
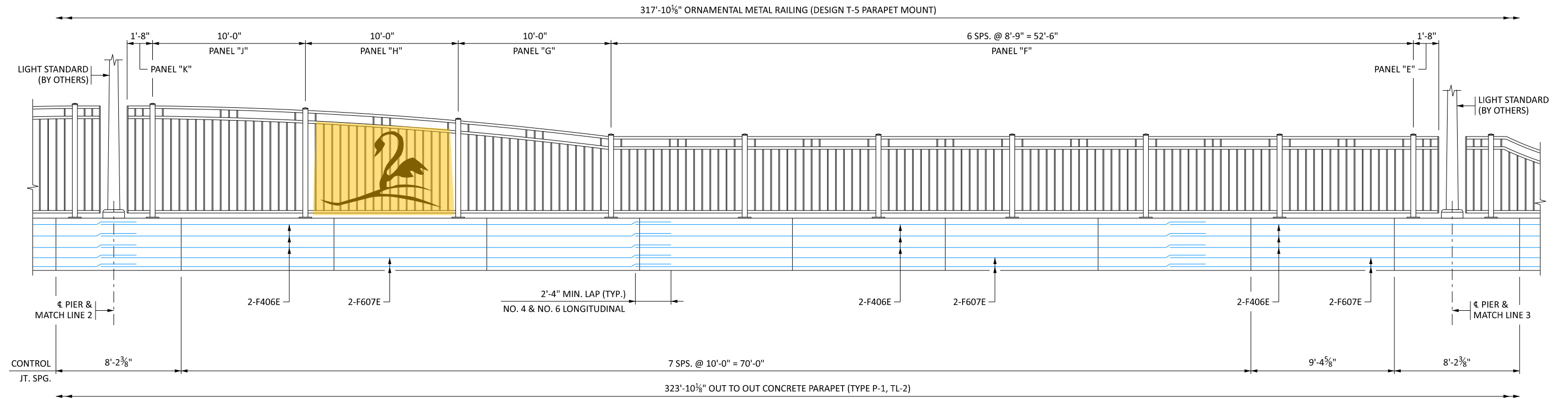

INSIDE ELEVATION CONCRETE PARAPET & ORNAMENTAL RAILING
 WEST BARRIER SHOWN (EAST BARRIER SIMILAR)

NORTH END OF WEST BARRIER

Exhibit C - Metal Railing Swan Emblem

MAINTENANCE BY CITY OF MONTICELLO

- NOTES:**
- SEE SHEET NO. XX FOR CONCRETE BARRIER AND REINFORCEMENT DETAILS.
 - SEE SHEET NO. XX FOR ORNAMENTAL METAL RAILING DETAILS.
 - SEE SHEET NO. XX FOR RAIL PANEL DETAILS.
 - ① MEASURED ALONG INSIDE FACE OF PARAPET.
 - ② 2" AT ALL TEMPS.

REV. NO.	DATE	REVISION DESCRIPTION	BY	I HEREBY CERTIFY THAT THIS PLAN WAS PREPARED BY ME OR UNDER MY DIRECT SUPERVISION AND THAT I AM A DULY LICENSED PROFESSIONAL ENGINEER UNDER THE LAWS OF THE STATE OF MINNESOTA	CERTIFIED BY: NAME: BRANDON L. DAY LICENSED PROFESSIONAL ENGINEER DATE LIC. NO.: 56027	TITLE: CONCRETE PARAPET & METAL RAILING ELEV. (2 OF 2)	DES: _____ CHK: _____	DR: BEP CHK: _____	APPROVED:	BRIDGE NO. 86803
								SHEET NO. 15 OF __ SHEETS		

TIME : 9:26:43 PM
 PLOTTED : 11/24/2025
 PATH & FILENAME: c:\project\se\pw_working\pove2\1538256.br86803_BEP.dgn

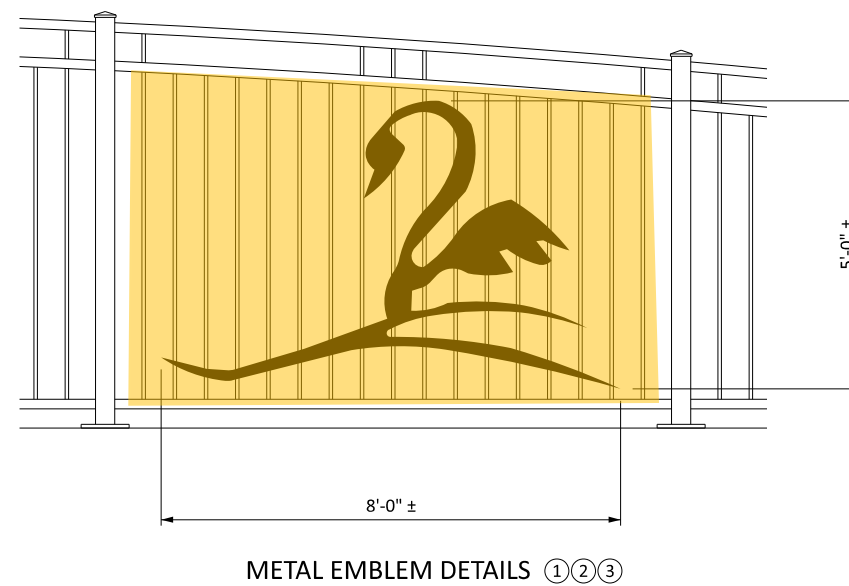
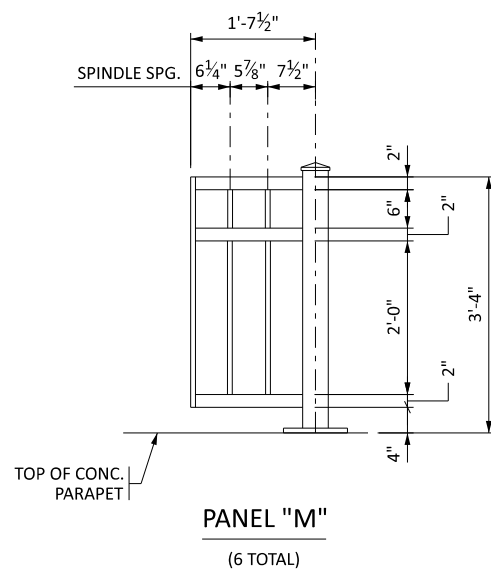
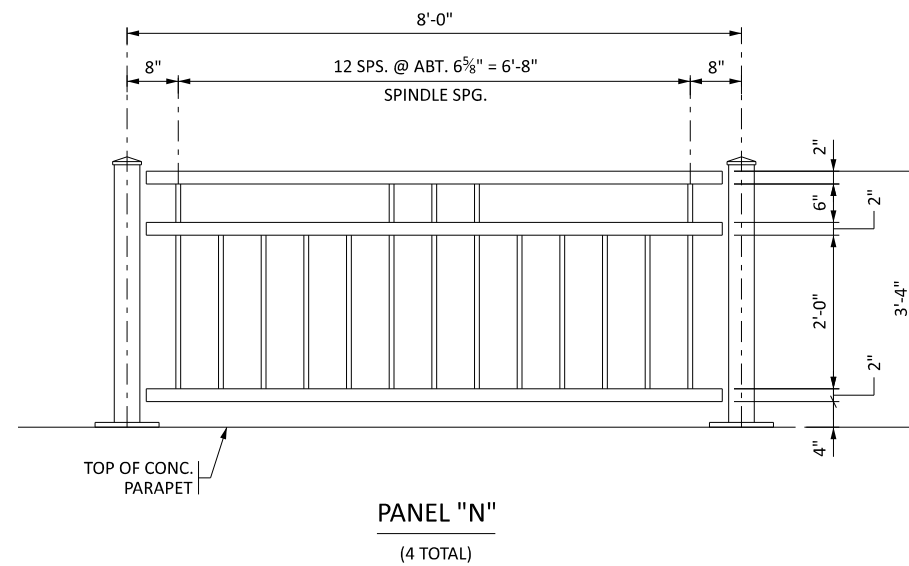
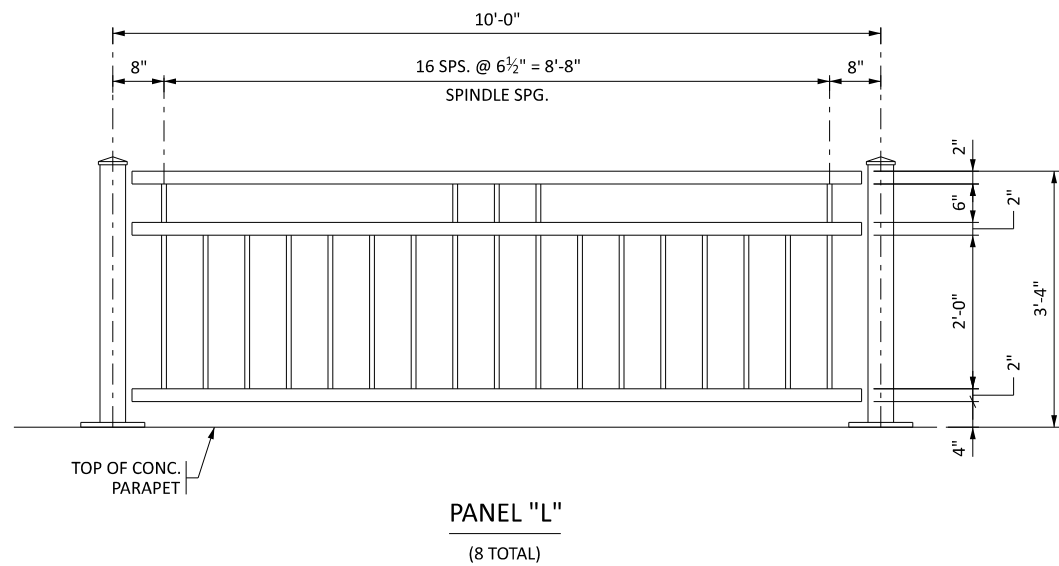

- NOTES:**
- SEE SHEET NO.S XX-XX FOR PANEL LOCATIONS.
 - SEE SHEET NO. XX FOR PANEL DETAILS.
 - ① METAL RAILING EMBLEM INCLUDED IN ITEM "METAL EMBLEM". SEE SPECIAL PROVISIONS. EMBLEM CADD FILE AVAILABLE FOR FABRICATION PURPOSES.
 - ② ALL POINTS TO BE ROUNDED TO MIN. 3/4" RADIUS.
 - ③ WELD METAL EMBLEM TO OUTSIDE (HIGHWAY SIDE) FACE OF RAILING.

Exhibit C - Metal Railing Swan Emblem

MAINTENANCE BY CITY OF MONTICELLO

REV. NO.	DATE	REVISION DESCRIPTION	BY	I HEREBY CERTIFY THAT THIS PLAN WAS PREPARED BY ME OR UNDER MY DIRECT SUPERVISION AND THAT I AM A DULY LICENSED PROFESSIONAL ENGINEER UNDER THE LAWS OF THE STATE OF MINNESOTA	CERTIFIED BY: NAME: BRANDON L. DAY LICENSED PROFESSIONAL ENGINEER DATE LIC. NO.: 56027	TITLE: ORNAMENTAL METAL RAILING DETAILS (3 OF 3)	DES: _____ CHK: _____	DR: BEP CHK: _____	APPROVED: _____	BRIDGE NO. 86803
SHEET NO. 21 OF __ SHEETS										